

4

3

DWG NO.

SH 1

REV

1

D

D

&L · φ " &* * [* " + *] · ∇ " * & \$ [% " +]
✓ φ ") + + [% (" () L ; & s

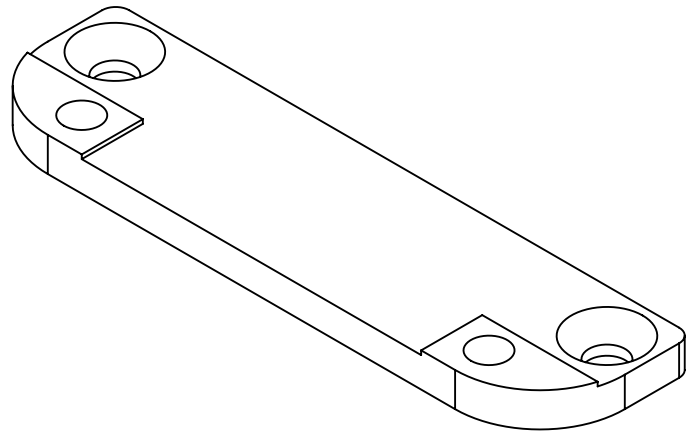
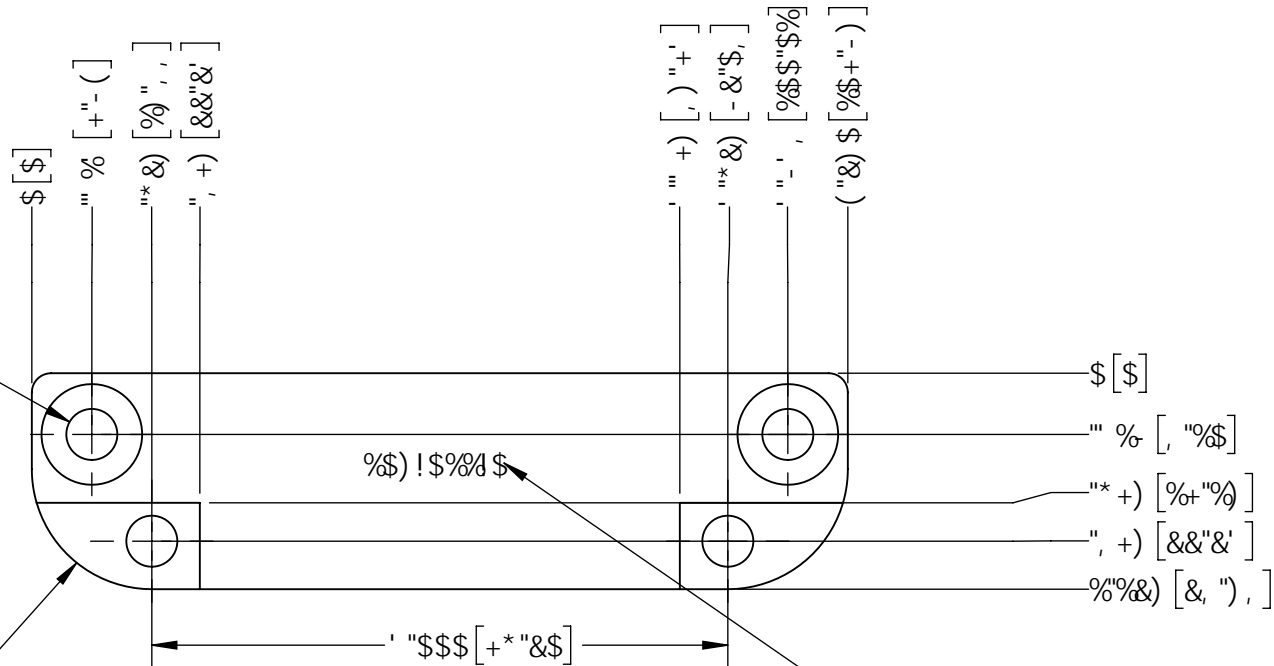

DFC : @ 5 B 8 H K F I < C @ G @ 5 G 9 F 7 I H H C @ 9 F 5 B 7 9
5 B 8 : B G < 5 7 7 9 D H 5 6 @

G H 5 A D D 5 F H B I A 6 9 F
K < 9 F 9 G < C K B

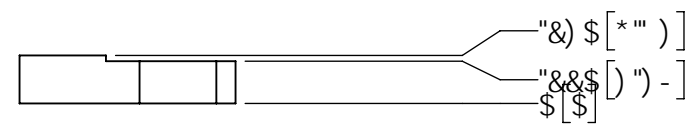
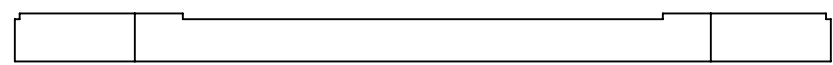

C

C

B

B

&L · φ " &* * [* " + *] · ∇ " * & \$ [% " +]

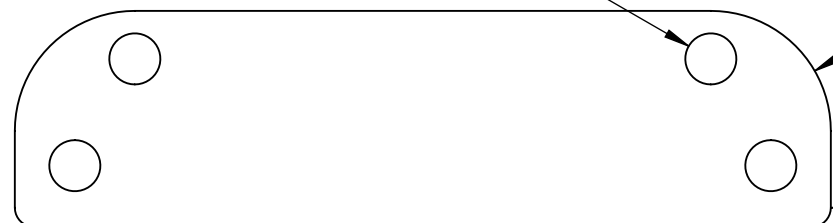

F " * &) [% " , ,]

F " % \$ \$ [& " ()

B C H 9 G
A 5 H @ " \$ (' G ' G'
: B G < . 9 J 9 B ' H A 6 @ 8 : B G < : F 9 9 C : ' 6 I F F G
D 5 7 ? . 7 @ 5 B # 8 F M

D 5 F H G 5 A 9 ' 5 G L * 6 ' A C I B H D @ 5 H 9 & F 8 ! &

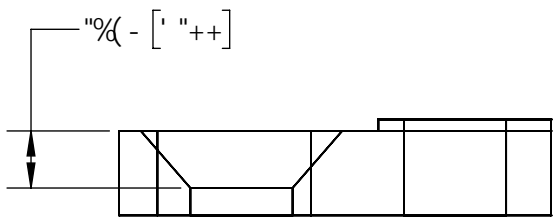

A

A

| | | | |
|---|--|---|--|
| <p>1b Ygg Ch\Yfkl gY GdYWZlYX</p> <p>AUW b b H' YfUbwg</p> <p>5b ' Y - ' ') s</p> | | <p>PROPRIETARY NOTICE: THE INFORMATION CONTAINED IN THIS DRAWING IS THE SOLE PROPERTY OF JOESCAN IT IS NOT TO BE USED, REPRODUCED, OR DISCLOSED IN WHOLE OR IN PART TO ANYONE WITHOUT THE WRITTEN PERMISSION OF JOESCAN CORPORATION</p> | |
| <p>1b Ygg Ch\Yfkl gY GdYWZlYX</p> <p>! 8 aYbg cbg' Udd' m UzhYf' Z b g\</p> <p>! 6fYU_ U' ' g\Ufd' Wefbyfg' hc' A b' s' ss%z' ALI' s' s' s'</p> <p>! 8c' bch' aUW bY' gheW' g nYg</p> <p>! 5' ' aUW bYX' gi fZUWg' hc' VY' %' ' ' fFACL' \</p> <p>cf' VVhhYf</p> <p>' fX' 5b ' Y' Df' c' YW tBc' bch' gWU' Y' XfUk b </p> <p>! 8 aYbg cbg'</p> <p>UfY' b' bWYg</p> | | <p>APPROVALS</p> <p>DATE</p> <p>DFT:</p> <p>CHK:</p> <p>ENG: J.KOLLMANN</p> <p>5/5/2022</p> <p>APR:</p> | <p>JoeScan</p> <p>TITLE PA00105-011-00_ X6B mount two hole</p> <p>SIZE B</p> <p>CAGE NO.</p> <p>DWG. NO. PA-00105-011-00</p> <p>REV \$</p> <p>SCALE = NONE</p> <p>WT:</p> <p>SHEET 1 OF 1</p> |

4

3

2

1