

# JS-50 MX

spec sheet

# JoeScan

## LONG RANGE LINEAL 3D LASER SCANNER



SINGLE CAMERA

PULSED LASER

## SIMPLE. RELIABLE. COST-EFFECTIVE.



SINGLE CABLE CONNECTOR



QUIKLOCK MOUNT

# MADE FOR SAWMILLS

	NEAR	FAR	
DATA	Resolution	+/- 0.03" ( +/-0.8mm )	+/- 0.08" ( +/-2.0mm )
	Density	62 points per inch ( 24 points per cm )	20 points per inch ( 8 points per cm )
	Max Speed	2000 profiles per second	
	Points per Profile	Up to 1456	
	Power	IEEE 802.3 af Power over Ethernet	
GENERAL	Laser Type	Pulsed, Class 3R	
	Laser Color	Visible red	
	Computer	Single standard PC per system	
	Data Interface	Gigabit Ethernet	
	Weight	7 lbs ( 3.2kg )	
	Operating Temp	0° to 120°F ( -20° to 50°C )	
	Storage Temp	-40° to 176°F ( -40° to 80°C )	
	Lighting	Fully operational between indoor lighting (no sunlight) and complete darkness	

### MACHINE CENTERS

- Bucking/Merchandising
- Gang
- Sharp Chain



### DROP-IN UPGRADE MOUNT

Available drop-in mount allows JS-50 MX to use existing JS-25 mount rings.



# MADE FOR SAWMILLS

# JS-50 MX

spec sheet

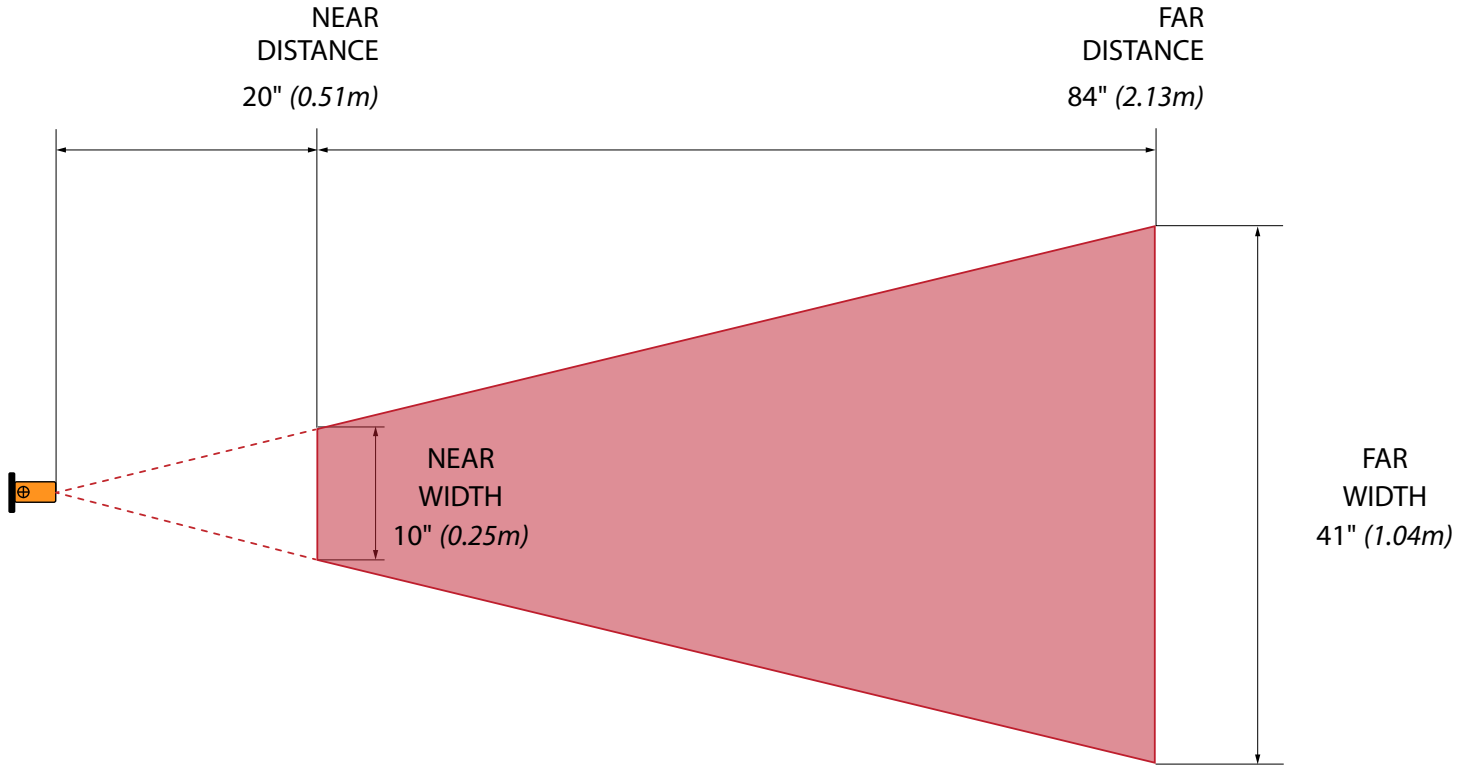

*JS-50 MX can collect data outside of these ranges with reduced specs*

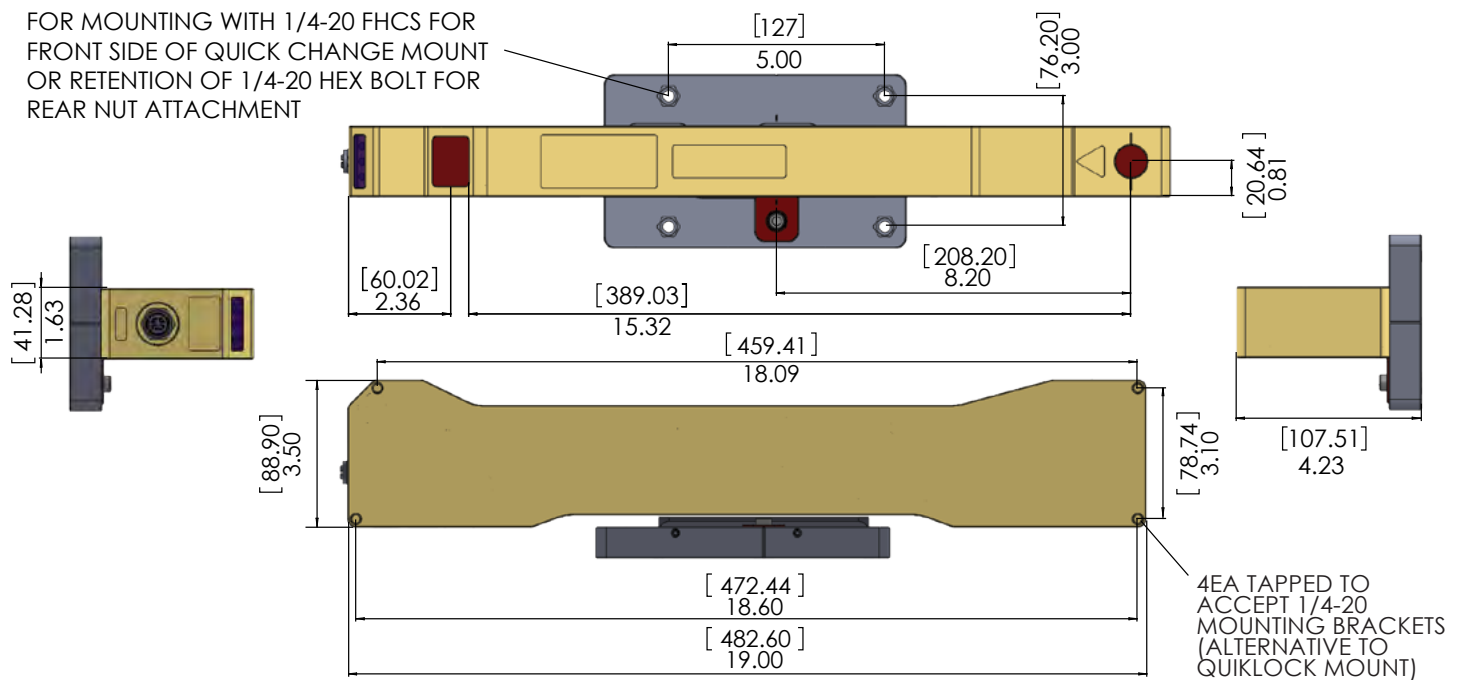

3D MODELS AVAILABLE AT JOESCAN.COM

# JS-50 MX

spec sheet

# MADE FOR SAWMILLS



**5 YEAR WARRANTY**  
**10 YEAR SUPPORT**  
**LIFETIME COMMITMENT**

At JoeScan, we make scanners for sawmills.

Our only focus is to deliver results for our sawmill partners. We have more than 5,000 scanners installed in sawmills all over the world, and our very first scanners are still running strong, over 20 years later.

Since 2002, we've learned what works for sawmills.

We keep our solutions simple.

We make sure that everything we make can stand up to the rigors of the sawmill environment, day after day, year after year.

And we work hard to deliver cost-effective scanning solutions for the sawmill industry.

Because we are committed to serving our partners, JoeScans are made for sawmills. If you'd like to become one of our partners, we are ready to prove it to you.

## Let's chat.

4510 NE 68<sup>th</sup> Drive, Suite 124  
Vancouver, WA, USA 98661

+1.360.993.0069

[info@joescan.com](mailto:info@joescan.com)